

AAAG

PACKAGING

Quality Over Quantity

Certified Packaging Partner

Table of Contents

1 About Us

1.1 About AAG	4
1.2 Our Clients	5
1.3 Value Propositions	6
1.4 Vision & Direction	7
1.5 Certifications	8

2 Production Department

2.1 Performance	11
2.2 Finishing	12

3 Products

3.1 RSC Box	15
3.2 Die-Cut Box	17
3.3 Symbol Box	19
3.4 Brand Box	20

4 Services

4.1 Services Process	22
4.2 Others	23

1

About Us

AAG Packaging



AAG Packaging Co., Ltd

Crafted in Thailand.
Delivered Worldwide.

Scalable. Reliable. Cost-Efficient.

- Certified corrugated packaging manufacturer
- End-to-end capability (design → delivery)
- Built for high-volume global supply chains

Our Clients



Trust by
Leading Brands

From local to international business



Delivering Measurable Value



Lower cost through material & process optimization



Consistent quality at scale



Reliable lead time and delivery



Flexible, solution-driven collaboration

Vision & Direction

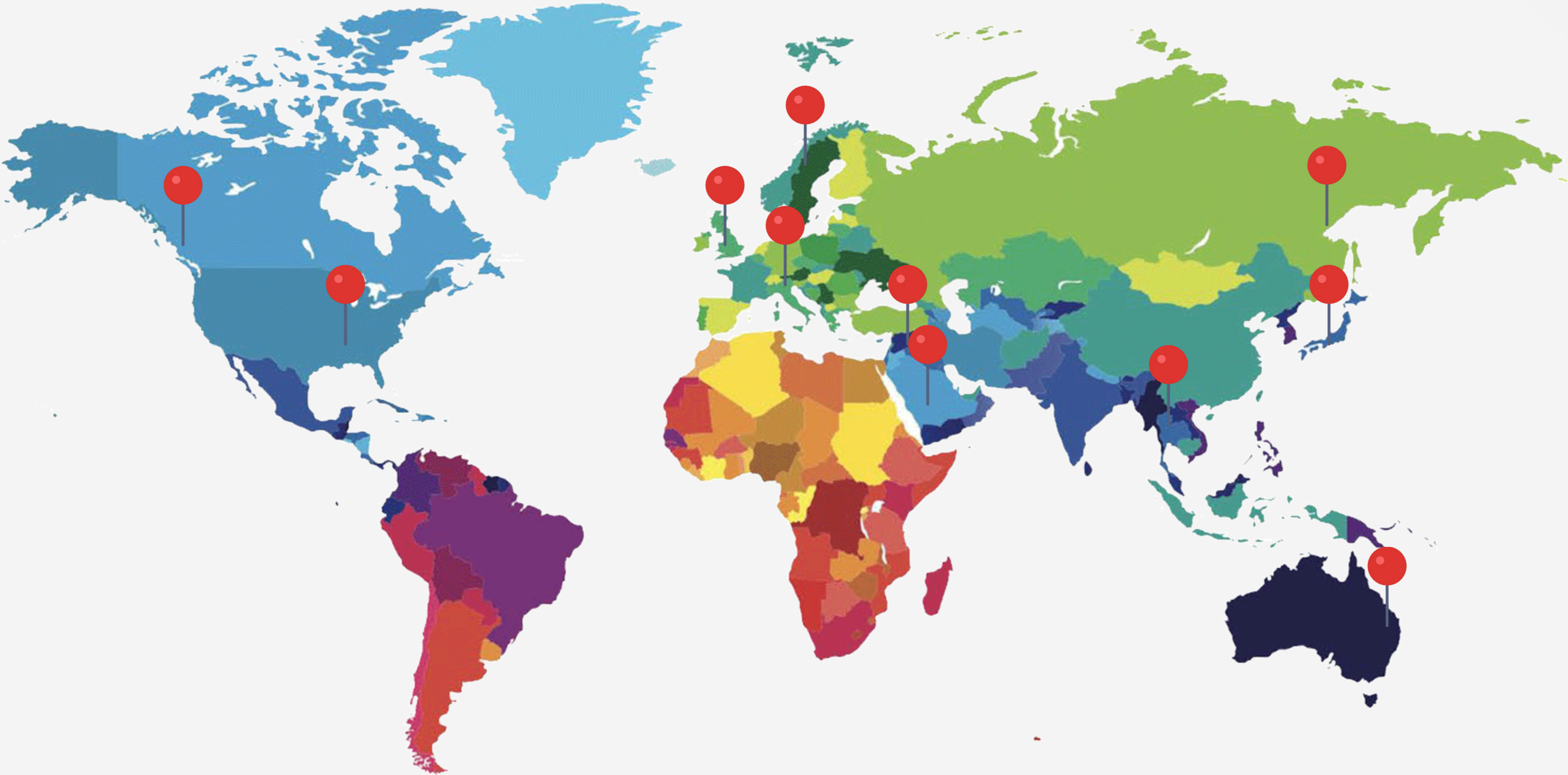

Local Strength



Global Standard

Enable brands through high-quality packaging

Scale to international partnerships

Continuous innovation and efficiency improvement

Certificate TH25/0000036
The management system of
AAG Packaging Co., Ltd.

99/63, Tambon Bang Rakam, Bang Len District, Nakhon Pathom 73130, Thailand
has been assessed and certified as meeting the requirements of
ISO 9001:2015
For the following activities
Manufacture of Printed and Non Printed Corrugated Box

This certificate is valid from 09 January 2025 until 08 January 2028 and remains valid subject to satisfactory surveillance audits.
Issue 1. Certified since 09 January 2025

L. Moran

Authorised by
Liz Moran
Business Manager
SGS United Kingdom Ltd
Rossmore Business Park, Ellesmere Port, Cheshire, CH65 3EN, UK
t +44 (0)151 350-6666 - www.sgs.com

This document is an authentic electronic certificate for Client business purposes use only. Printed version of the electronic certificate are permitted and will be considered as a copy. This document is issued by the Company subject to SGS General Conditions of certification services available on Terms and Conditions | SGS Attention is drawn to the limitation of liability, indemnification and jurisdictional clauses contained therein. This document is copyright protected and any unauthorized alteration, forgery or falsification of the content or appearance of this document is unlawful.

Certificate TH24/00000796
This is to certify that
AAG Packaging Co., Ltd.

99/63, Tambon Bang Rakam, Bang Len District, Nakhon Pathom, 73130, Thailand

SITE CODE 10014852
has been assessed and certified as meeting the requirements of
Global Standard for Packaging Materials
Issue 6: August 2019
Achieved Grade: A
Audit Programme: Announced
For the following activities:
Flexography printing, Die Cutting, Stitching, Gluing and Folding of Corrugated Carton for Indirect Contact with Food Products
EXCLUSIONS: None

Product Categories: 2, 7
AUDITOR NUMBER: 20262
Date of Evaluation: 07 October 2024
Certificate Issue Date: 07 November 2024
Re-Evaluation Due Date 07 October 2025
Certificate Expiry Date: 18 November 2025
This certificate supersedes all other certificates bearing this certificate number with earlier certificate issue dates.

If you would like to give feedback on the BRCGS Standard or the audit process directly to BRCGS, please contact: enquiries@brcgs.com or use the BRCGS reporting system at <https://tellusbrcgs.whistleblownetwork.net>. To verify certificate validity, please visit <https://directory.brcgs.com>.

L. Moran

Authorised by
Liz Moran
Business Manager
This certificate remains the property of
SGS United Kingdom Ltd
Rossmore Business Park, Ellesmere Port, Cheshire, CH65 3EN, UK
t +44 (0)151 350-6666 - www.sgs.com

This document is an authentic electronic certificate for Client business purposes use only. Printed version of the electronic certificate are permitted and will be considered as a copy. This document is issued by the Company subject to SGS General Conditions of certification services available on Terms and Conditions | SGS Attention is drawn to the limitation of liability, indemnification and jurisdictional clauses contained therein. This document is copyright protected and any unauthorized alteration, forgery or falsification of the content or appearance of this document is unlawful.

Page 1 / 1

Global Standards. Proven Systems.

“We are dedicated to developing innovative packaging solutions that prioritize quality, meet consumer needs, and comply with all relevant regulations to ensure the highest level of safety”

- **BRCGS** Grade A (SGS-certified)
- **ISO 9001:2015**
- Structured quality and compliance framework



Built for Partnership

Certified quality, export-ready

Competitive cost structure

Fast turnaround, reliable execution

Flexible across formats and volumes

Sustainability-driven development

20+ years industry expertise



2

Production Department

From our factory to your customers



AAG
PACKAGING

Operations

High-Capacity Manufacturing Platform

Modern machinery and automation systems

Multi-line production capability

Designed for high-volume scalability

Continuous capacity expansion

Performances

Performance from 2025

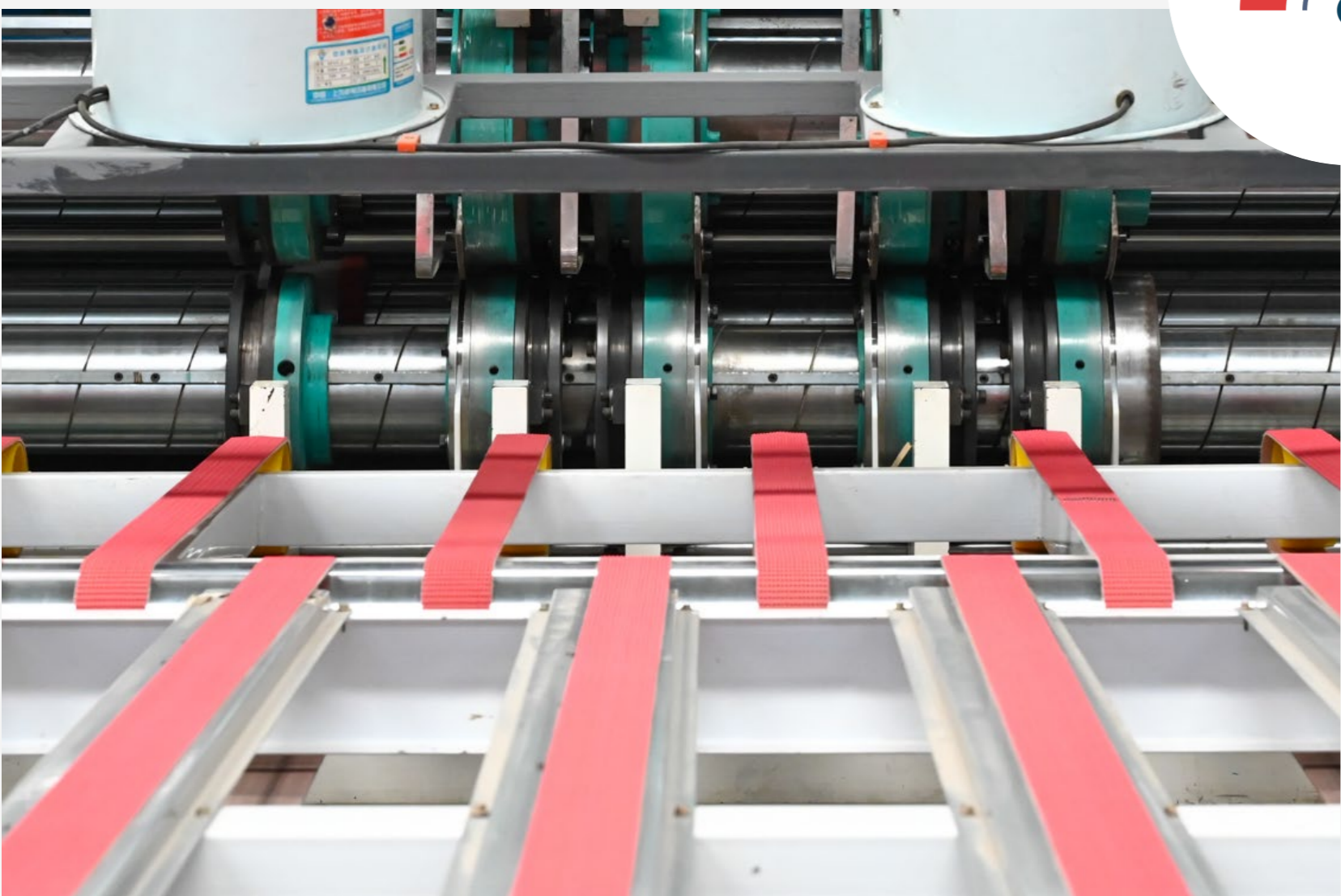

Speed x Scale x Consistency

~9,000 sheets/hour of printing
Stable, high-quality output

Precision at Volume

~4,500 pcs/hour die-cut
Automated folding & gluing
Consistent quality across runs



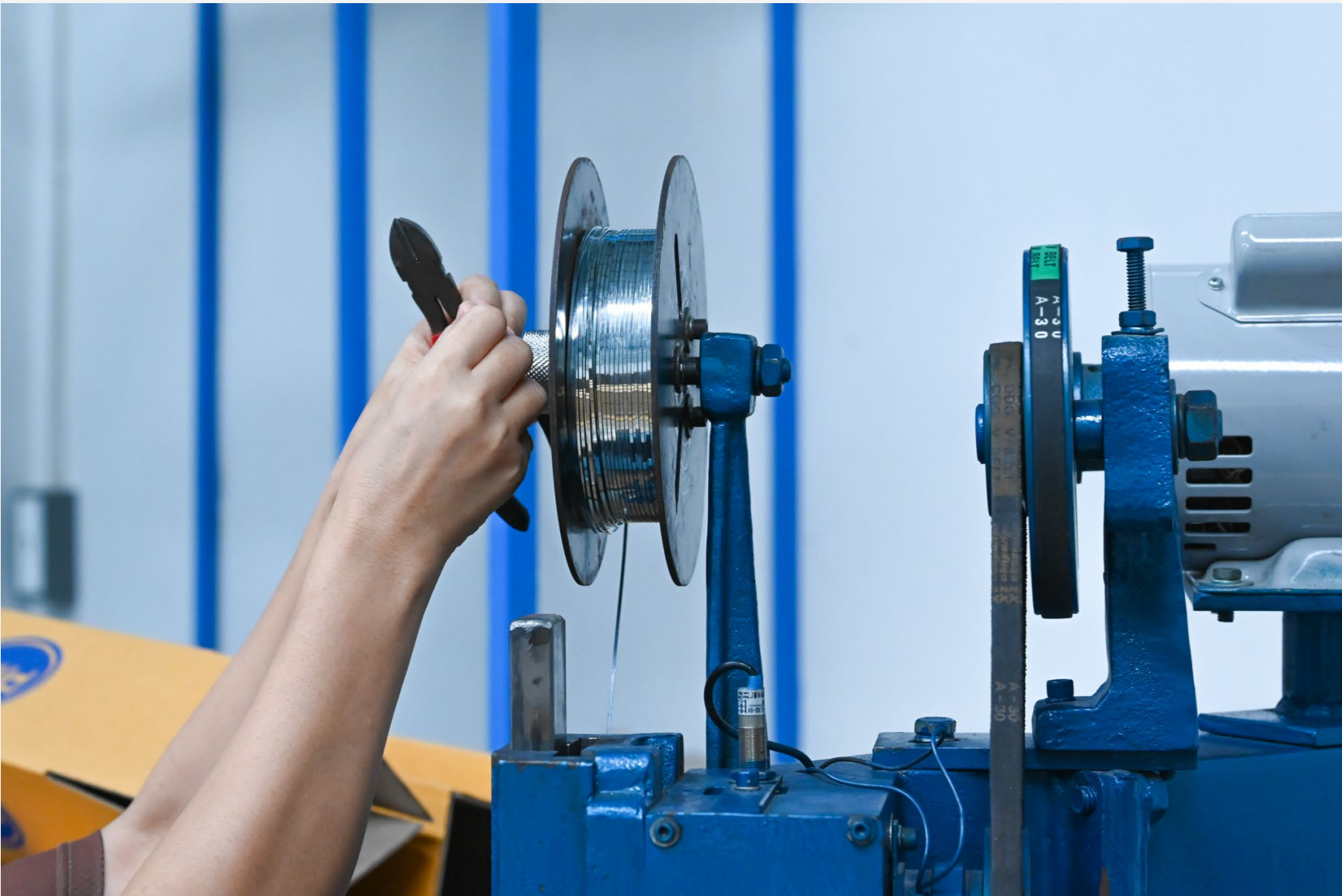

Efficient,
Logistics-Ready

Automated tying & bundling
Stapling capability

**Optimized for handling &
transport**

3

Products

Standard to Fully Customized

Products

Popular Box



Opens on the top or bottom.
Use adhesive tape to close.



Closed



Opened

RSC (Regular Slotted Container)

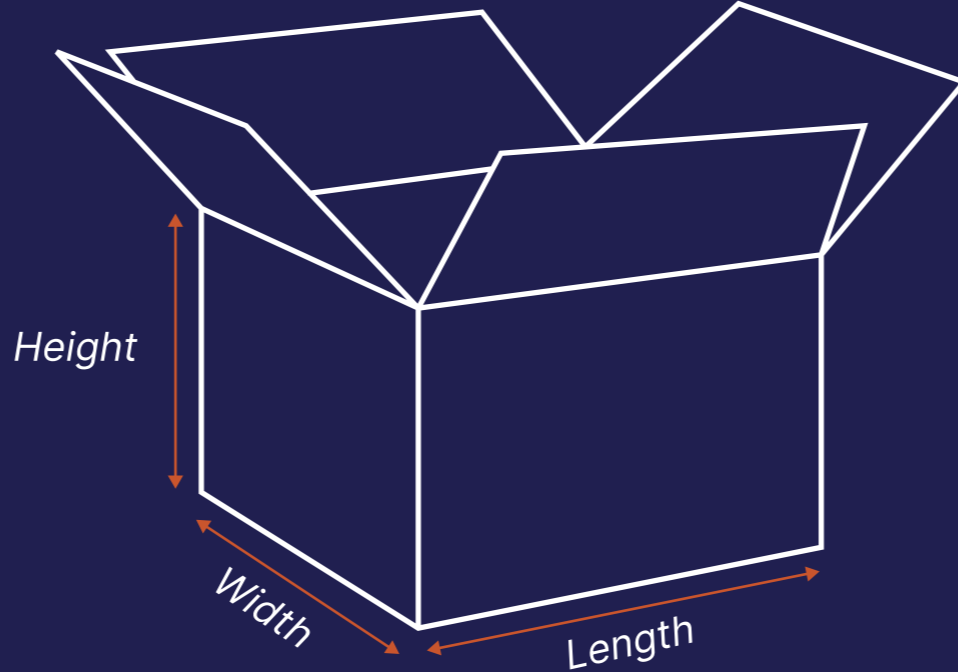

The most common box style. Highly efficient design for many applications. All flaps are the same length, and the two outer flaps (normally the lengthwise flaps) are one-half the container's width, so that they meet at the center of the box when closed.



00
9.5 x 14 x 6 cm



0 + 4
11 x 17 x 10 cm



CD
15 x 15 x 15 cm



2B
17 x 25 x 18 cm

Common Box

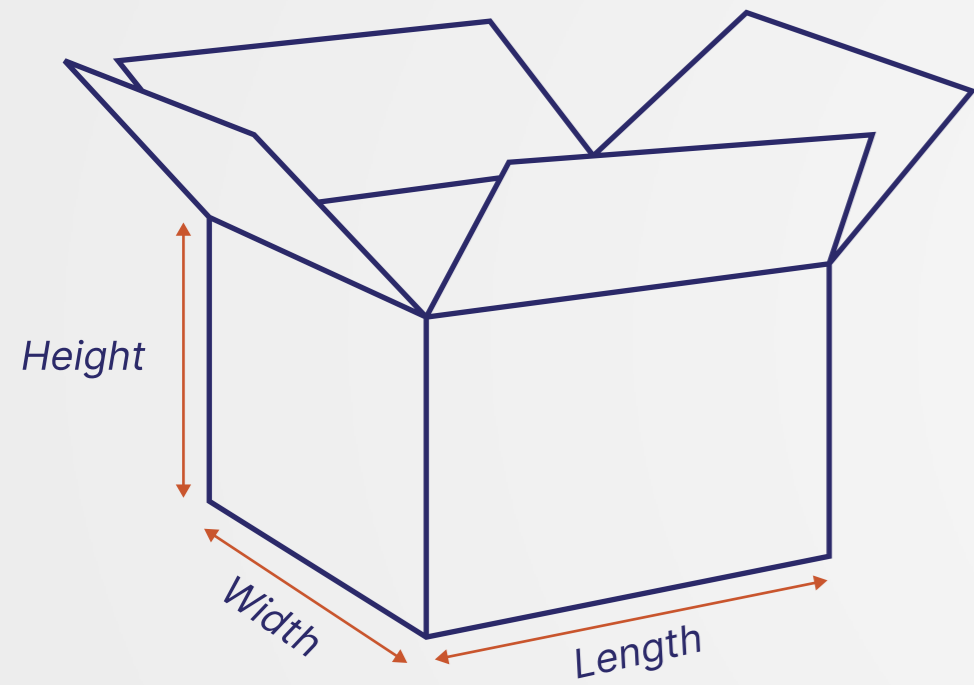

2D

25 x 35 x 28 cm



E

24 x 40 x 17 cm



G

31 x 36 x 26 cm



M+

27 x 43 x 20 cm



RSC

61 x 75 x 10 cm



RSC

30 x 45 x 35 cm



RSC

15 x 20 x 100 cm



RSC

20 x 35 x 100 cm

**We can do any kinds of corrugated box packaging and any types of jobs related to corrugated paper.*

Die Cut Box

DIE-CUT BOX

(Custom Die-cut cardboard)

Die cut boxes get their name from a machine known as a die cutter or die press.

This machine cuts corrugated cardboard into boxes. As a result of the die press, die cut boxes can be cut into a wider array of shapes and styles than RSC boxes.



A specially designed box created with a die cut press or machine.



Die Cut Box
61 x 75 x 10 cm



Die Cut Box
61 x 75 x 10 cm



Die Cut Box
61 x 75 x 10 cm



Die Cut Box
15 x 100 x 20 cm

Die Cut Box

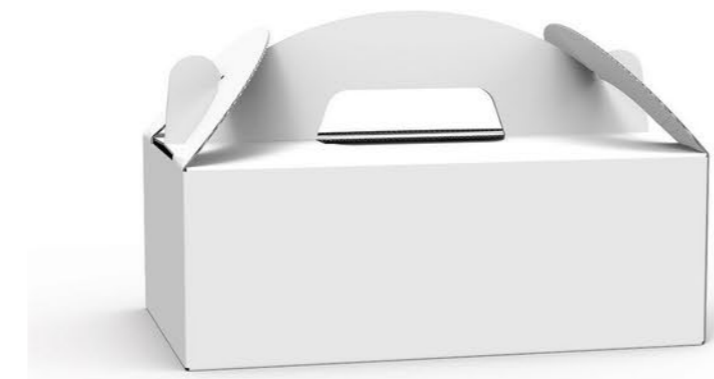

Die Cut Box
10 x 35 x 20 cm



Die Cut Box
14 x 12 x 7 cm



Die Cut Box
30 x 30 x 7 cm



Die Cut Box
22 x 22 x 5 cm



Die Cut Box
61 x 75 x 10 cm



Die Cut Box
30 x 45 x 35 cm



Die Cut Box
15 x 20 x 100 cm



Die Cut Box
20 x 35 x 100 cm



Die Cut Box
61 x 75 x 10 cm

**We can do any kinds of corrugated box packaging and any types of jobs related to corrugated paper.*

**We can do any kinds of corrugated box packaging and any types of jobs related to corrugated paper.*

Symbol Box



Symbol
43 x 33 x 39 cm



Symbol
24 x 40 x 17 cm



Symbol
43 x 33 x 39 cm



Symbol
15 x 75 x 17 cm



Symbol
15 x 35 x 45 cm



Symbol
43 x 33 x 39 cm

SYMBOL BOX
(Packaging with Symbol)

These packing symbols are recognized internationally and provide information about the product inside in an easy and comprehensible way.



*Ensure safety of your product
Alerting receivers or transporters*

**We can do any kinds of corrugated box packaging and any types of jobs related to corrugated paper.*

OEM BRAND BOX

(Original Equipment Manufacturer)

Helping to build your brand image and making your company identity better remembered.



You can design a special box for your company's products.

Brand Box



Kway

33 x 25.5 x 6.5 cm



Term Suk

29 x 33 x 8 cm



Simple & Raw

40.5 x 29 x 6.5 cm

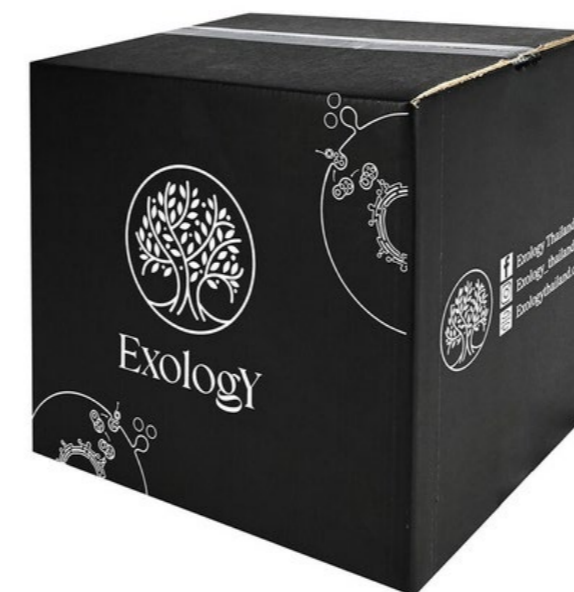

Exology

43 x 33 x 39 cm



Quinn

30 x 20 x 11 cm



Sunford

35 x 23 x 21 cm

4

Services

End-to-End Execution

Integrated workflow reduces lead time

We focus on after-sales service, which makes customers believe in on-time delivery with quality products, factory prices and customer's best interests, which is our primary goal.



Consult

Count on

- Single partner
- Full accountability



Planning

Worry Free

- 20+ years expertise
- Material optimization
- Structural efficiency



Print & Package

Consistent Output. Controlled Process

- Standardized production systems
- Tight quality control
- Reliable repeatability



Deliver

On Time. In Full

- Reliable logistics execution
- Safe handling and transport
- Built for scale and consistency

Others

Sustainability

Reduce. Optimize. Improve.

- 10–20% material reduction (design-driven)
- Increased recyclable materials (responsible sources)
- Lower environmental impact (recycling water)
- Transition to alternative energy 10% > 80% (Solar cell)

KPI Performance

Operational Excellence.

- Defect rate: < 0.5%
- OTIF: ≥ 98%
- Lead time: 10–15 days
- Sampling: 2–4 weeks



The logo for AAG Packaging features the letters 'AAG' in a large, bold font. The first 'A' is gold, the second 'A' is orange, and the 'G' is dark blue. Below 'AAG' is the word 'PACKAGING' in a smaller, gold, sans-serif font. The letter 'G' in 'PACKAGING' is replaced by a stylized icon of a cardboard box with a blue and orange design.

AAG PACKAGING



AAG Packaging Co. Ltd.

99/63 Moo 5 Bangrakham Sub-District, Banglen City, Nakhon Pathom 73130, Thailand

 +66 (0) 96-6588694

 @AAG36

 AAG packaging

 info@aagpackaging.com

 www.aagpackaging.com